

MTJ SERIES HYDRAULIC MOTOR

MTJ series motors have an advanced Geroller gear set, designed to accommodate high speed flow and pressure. These units have good stability at low speed, keeping high volumetric efficiency.



Features

- Advanced design for the Geroller gear set, allowing low pressure start-up, provides smooth and reliable operation together with high efficiency
- Output shaft fitted with needle roller bearings permitting high axial and radial forces
- Advanced design in flow distribution automatically compensating resulting in high volume efficiency and long life, providing smooth and reliable operation
- Low leakage rate, accurate internal timing. Commutator rotates 6x faster than shaft output speed giving high precision and reduces life-cycle cost, maintaining high volume efficiencies and ability to run smoothly at low speed

Specification

Type		65	80	100	125	160	200	230	250	295	315	375
Geometric Displacement (cm ³ /rev)		66.8	81.3	101.6	127	157.2	193.6	226	257	287.8	314.5	370
Max Speed (rpm)	Cont	667	543	439	350	283	229	247	216	196	178	152
	Int	842	689	553	441	355	289	328	287	254	235	199
Max Torque (Nm)	Cont	126	157	191	245	307	382	378	381	393	448	439
	Int	176	215	268	335	422	520	528	543	547	587	613
Max Output (kW)	Cont	8.3	8.8	7.9	8.9	8.9	9	9.9	9.3	8.7	8	7.6
	Int	13.9	14.4	13.5	14.1	15.6	15.7	17.9	16.5	15.6	14.3	14
Max Pressure (Bar)	Cont	140	140	140	140	140	140	120	110	100	100	90
	Int	190	190	190	190	190	190	165	155	145	135	125
	Peak	200	200	200	200	200	200	180	180	170	160	160
Max Flow (L/min)	Cont	45	45	45	45	45	45	57	57	57	57	57
	int	57	57	57	57	57	57	75	75	75	75	75

Continuous Pressure: Max value of operating motor continuously

Intermittent Pressure: Max value of operating motor in 6 seconds per minute

Peak Pressure: Max value of operating motor in 0.6 seconds per minute

MTJ SERIES HYDRAULIC MOTOR

Dimensions Mounting Data

Wheel Mount

Code: WS Ports A, B, 7/8 – 14 O-Ring
 Code: WD Ports A, B, G1/2
 Code: WM Ports A, B, M22x1.5

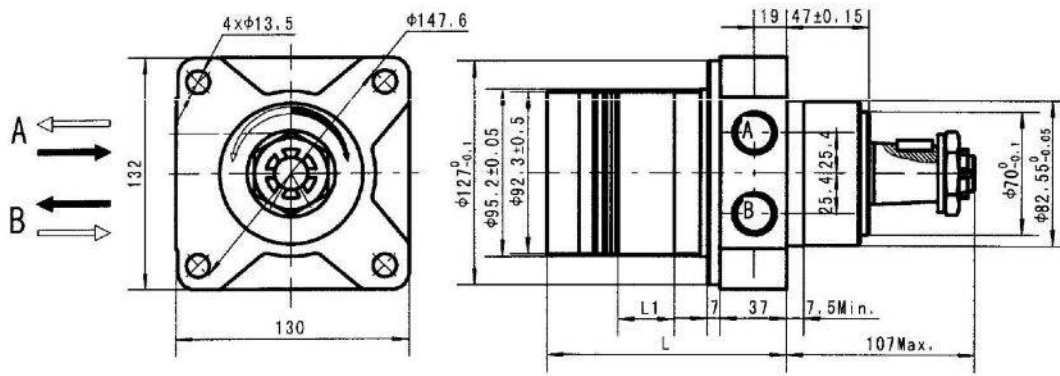

Displacement (cm ³ /rev)	65	80	100	125	160	200	230	250	295	315	375
L1 (mm)	13	16	20	25	30.5	38.1	44	50	56	62	74
L (mm)	115	118	122	127	132.5	140	146	152	158	164	176
Weight (kg)	9	9.1	10.4	10.6	10.9	11.3	11.8	12.2	12.6	12.9	13.4

Side Load (daN)

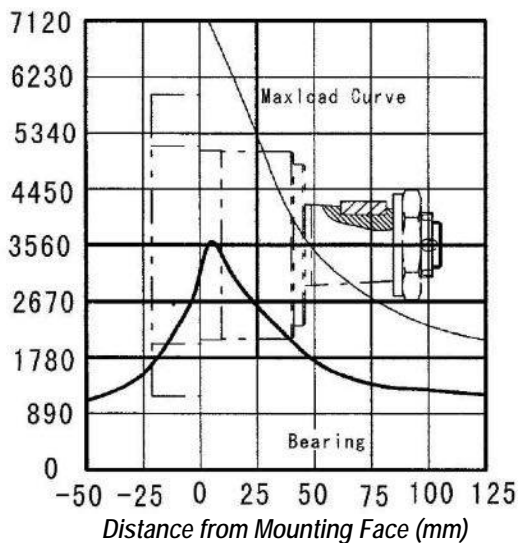

The bearing curve represents allowable bearing loads for an L₁₀ bearing life at 3x10⁶ revolutions

The maximum load curve is defined by bearing static load capacity. This curve should not be exceeded at any time including shock loads

ORDER INFORMATION

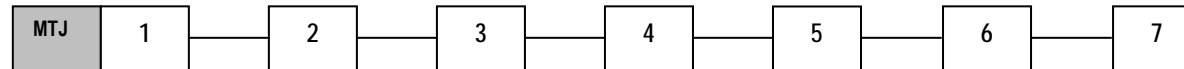

1	2	3		4		5		6		7	
Code	Disp	Flange, Pilot, Ports		Output Shaft		Rotation Direction		Paint		Unusually Function	
Omit	65	WS	4-Ø13.5 Wheel-Flange, Pilot Ø82.55x7, Port 7/8-14 O-Ring	T1	Cone-Shaft Ø35, Parallel Key B6x6x20	Omit R	Standard Opposite	00 Omit B S	No Paint Blue Black Silver Grey	Omit	Standard
	80			T2	Cone-Shaft Ø31.75, Woodruff Key Ø25.4x7.96						
	100	WD	4-Ø13.5 Wheel-Flange, Pilot Ø82.55x7, Port G1/2	T3	Cone-Shaft Ø31.75, Parallel Key 7.96x7.96x31.75						
	125			T4	Cone-Shaft Ø31.75, Parallel Key 7.96x7.96x25.4						
	160	WM	4-Ø13.5 Wheel-Flange, Pilot Ø82.55x7, Port M22x1.5	B	Cone-Shaft Ø31.75, Parallel Key 7.96x7.96x25.4						
200				Cylindrical Shaft Ø32, Parallel Key 10x8x45							
230											
250											
295											
315											
375											

Shaft Extensions for Dimensions Data

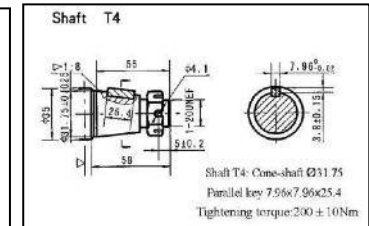
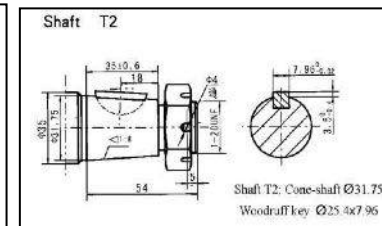
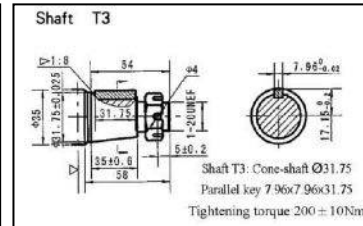
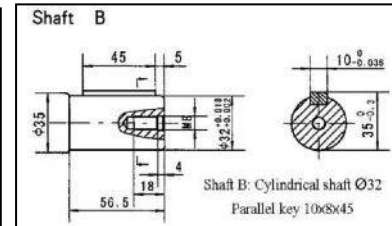
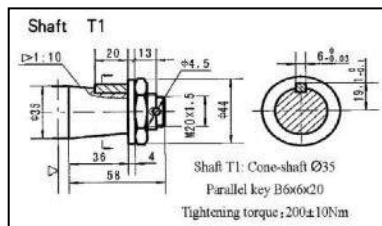

▷ Motor Mounting Surface

VALVES FOR HYDRAULIC MOTORS

SHUTTLE VALVE

Code: VSEFMDSE
 Max Flow 50L/min
 Max Pressure 350 Bar
 V1 – V2 ½" BSPP
 C3 ¼" BSPP

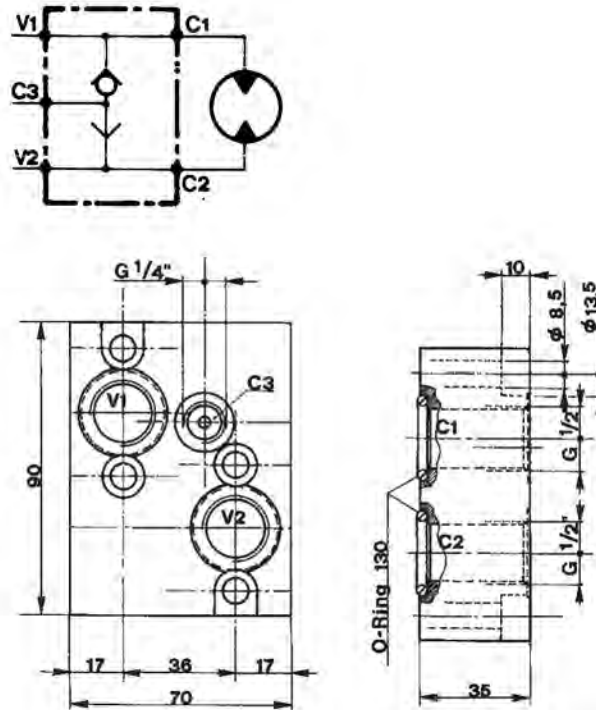

CROSSLINE RELIEF WITH BRAKE RELEASE SHUTTLE VALVE

Code: VS50FMDISE / 1Y04B
 50-130 Bar Adjustment
 Code: VS50FMDISE / 1Z04B
 100-280 Bar Adjustment

Max Flow 50L/min
 Max Pressure 250 Bar
 V1 – V2 ½" BSPP
 C3 ¼" BSPP

