

GM4 SERIES



SERIE GM4

GM4



PERFORMANCES TABLE TABELLA DELLE PERFORMANCE

GM4		400	500	600	800★	900	1000★	1100	1250	1300★
Displacement / Cilindrata	cm ³ /rev	402	503	616	793	904	1022	1116	1247	1316
Bore / Alesaggio	mm	42	47	52	59	63	67	70	74	76
Stroke / Corsa	mm	58	58	58	58	58	58	58	58	58
Specific torque / Coppia spec.	Nm/bar	6,27	7,85	9,61	12,40	14,10	16,00	17,40	19,50	20,50
Cont. Pressure / Press. Cont.	bar	250	250	250	250	250	250	250	250	250
Peak pressure / Press. Picco	bar	450	450	400	400	375	350	350	300	280
Cont. speed / Velocità Cont.	rpm	450	425	400	350	325	300	275	250	225
Max. speed / Velocità Max	rpm	600	600	550	550	450	400	400	400	350
Peak power / Potenza picco	kW	100	100	100	100	100	100	100	100	100

Approximative mass / Massa approssimativa	kg	100
---	----	-----

Motor casing oil capacity / Capacità olio corpo motore	l	6,5
--	---	-----

Max casing pressure / Pressione max. in carcassa	bar	5	peak picco	La pressione continua o media di lavoro va determinata in funzione della vita del motore (vita dei cuscinetti).
		1	continuous continuo	Continuous or average working pressure should be chosen in function of the required service lifetime (bearing lifetime).

★= Preferred motor type / Morote preferito

DIMENSIONS

DIMENSIONI

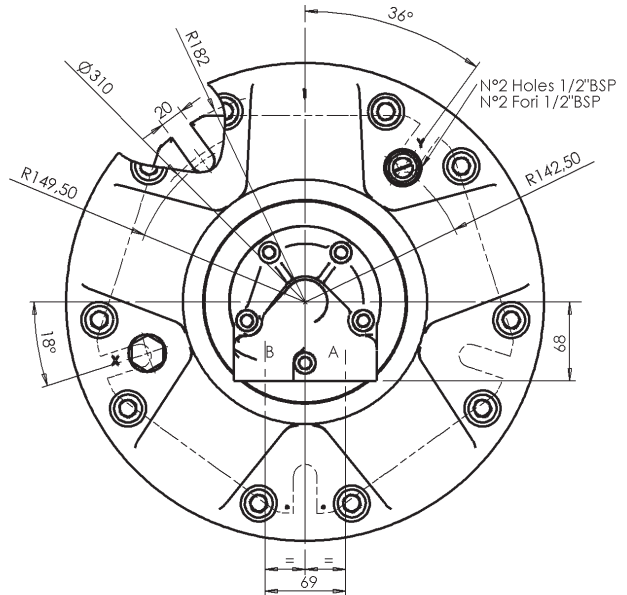
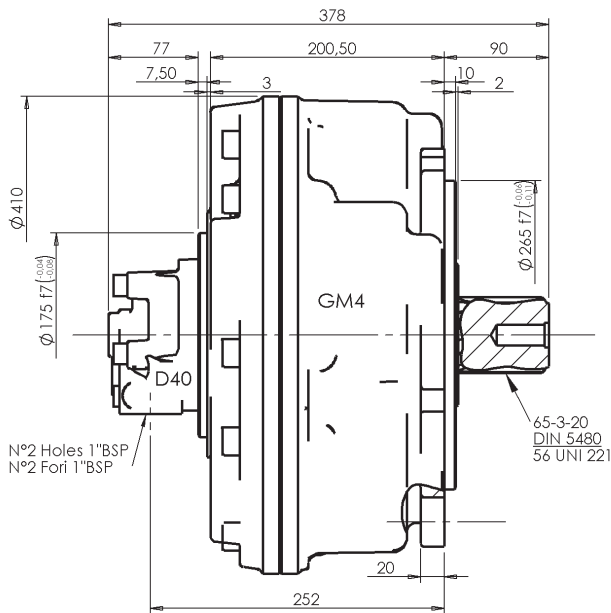

Flange and shaft dimensions are as in M5 series motors

Le dimensioni della flangiatura e degli alberi sono come nella serie M5.

SHAFTS

ALBERI

Splined DIN 5480 7
Calettato UNI 221 1

Tapered 2
Conico

Cylindrical 8
Cilindrico

Internal spline DIN 5480 9
Calett. intern. DIN 5482 3

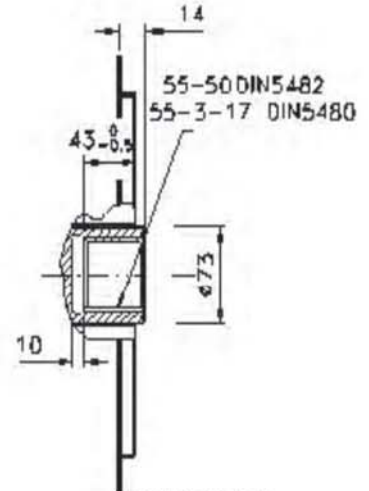
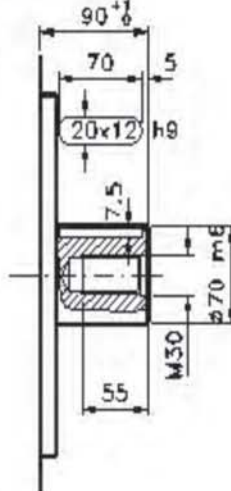
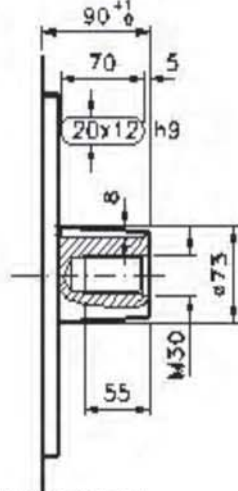
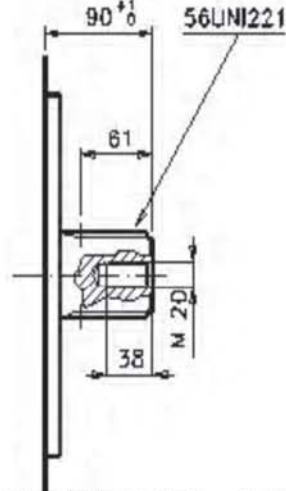

SPLINE DATA - CALETTATURE

ADAPTORS MANICOTTI

DIN	65-3-20 DIN 5480	55-2-26 DIN 5482	55-3-17 DIN 5480	56 UNI 221
d0	Ø60.0	Ø52.0	Ø51.0	d1 Ø56.0 +0.030 / +0 H7
d1	Ø65.0 +0.740 / +0 H14	Ø55.0 +0.300 / +0 H12	Ø55.0 +0.740 / +0 H14	d2 Ø65.0 +0.190 / +0 H11
d2	Ø59.0 +0.190 / +0 H11	Ø50.0 +0.160 / +0 H11	Ø49.0 +0.160 / +0 H11	A 10.0 +0.028 / -0.013 F7
A	Ø52.5	Ø3.5	Ø5.25	d3 Ø56.0 -0.010 / -0.029 g6
da	Ø54.101 H11	Ø46.902 H10	Ø43.807 H11	d4 Ø65.0 -0.100 / -0.190 d11
d3	Ø64.4 -0.190 h11	Ø54.5 -0.190 h11	Ø54.4 -0.190 h11	B 10.0 -0.013 / -0.028 f7
d4	Ø58.4 -0.740 h14	Ø49.0 -0.300 h12	Ø48.4 -0.620 h14	
B	Ø6.0	Ø3.5	Ø6.0	
db	Ø70.999 f8	Ø56.953 e9	Ø60.873 f8	

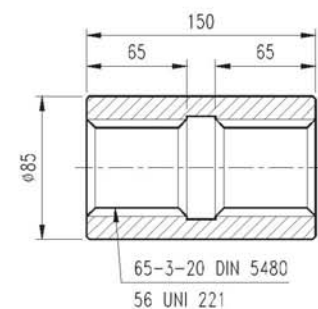

PERFORMANCE

The graphs indicate the typical performance characteristics of the **900 cc** motor operating with mineral oil with viscosity **40 cSt** at **50 °C**.

CARATTERISTICHE

I grafici si riferiscono alle caratteristiche del motore **900 cc** operando con olio minerale avente viscosità **40 cSt** a **50 °**

MECHANICAL EFFICIENCY
RENDIMENTO MECCANICO

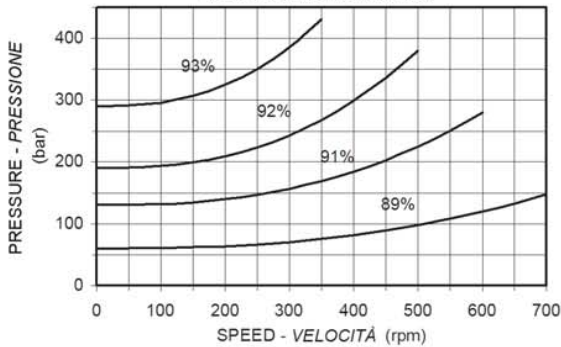

LEAKAGE RATE
DRENAGGIO

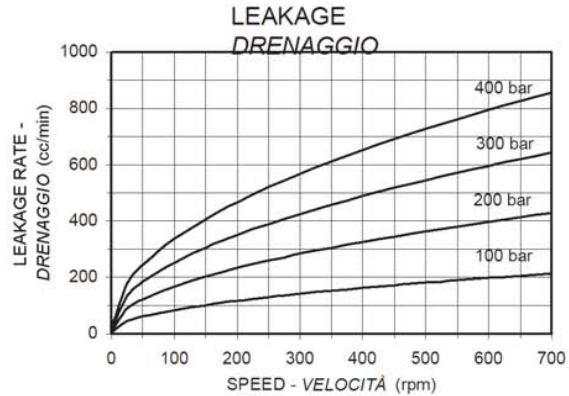

STARTING AND LOW SPEED TORQUE
COPPIA ALLO SPUNTO E A BASSA VELOCITÀ

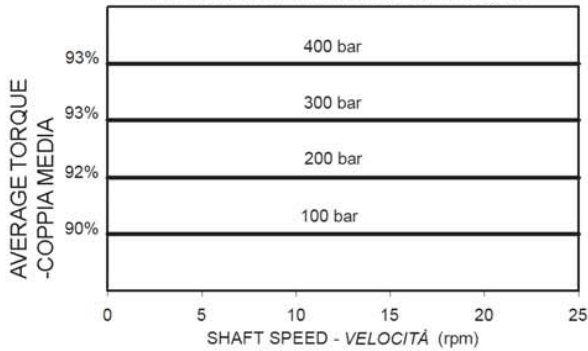

IDLING AND BOOST PRESSURE
CADUTA DI PRESSIONE

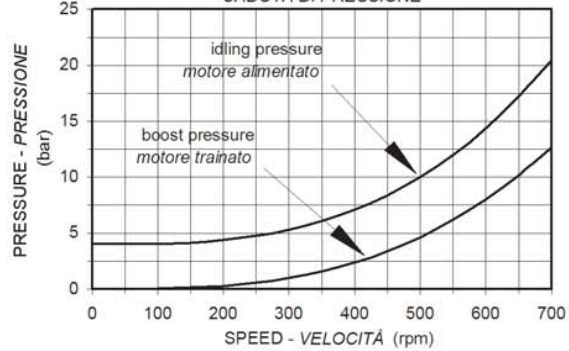

BEARING LIFETIME

The graph refers to the motor with the standard bearings. Note that the average lifetime of a bearing (B₅₀ lifetime) is approximately 5 times the B₁₀ lifetime.

VITA CUSCINETTI

Il grafico si riferisce ai motori con i cuscinetti standard. Notare che la vita media di un cuscinetto (vita B₅₀) è circa 5 volte superiore alla vita B₁₀.

MOTOR DISPLACEMENT - CILINDRATA MOTORE

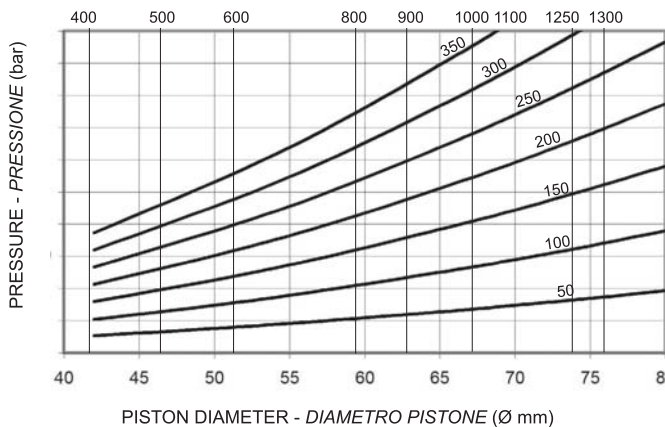

B₁₀ LIFETIME - VITA B₁₀

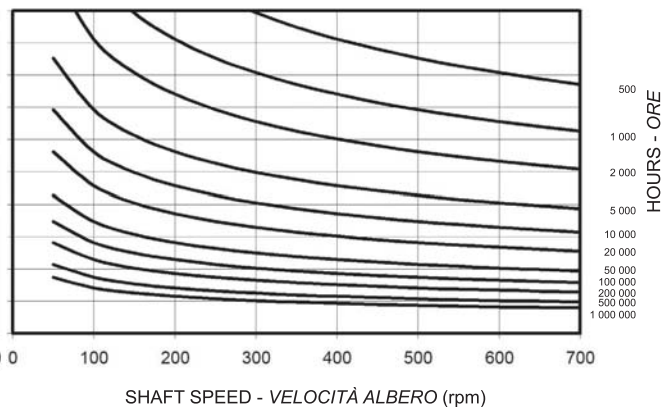

BEARING OPTIONS

Roller bearings (standard) - The lifetime of the roller bearings is given in the bearing lifetime graph.

Spherical roller bearings (option G) - the lifetime is 1.02 times the equivalent lifetime of the roller bearings.

For longer lifetimes contact our technical department.

OPZIONI CUSCINETTI

Cuscinetti a rulli (standard) - la vita dei cuscinetti a è ricavabile dal grafico di vita riportato.

Cuscinetti a rulli orientabili (opzione G) - la vita dei cuscinetti a rulli orientabili è 1,02 volte l'equivalente vita dei cuscinetti a rulli.

Per una durata maggiore consultare il Ns. ufficio tecnico

ORDER CODES

CODICI D'ORDINE

GM4 - ① ② ③ ④ + ⑤ ⑥ ; ⑦ ⑧

MOTOR CODE

1. Nominal displacement - see motor spec. table.

2. Shaft option:

- 7 = male 65-3-20 DIN 5480
- 1 = male 56 UNI 221
- 9 = female 55-3-17 DIN 5480
- 3 = female A 55-50 DIN 5482
- 2 = tapered keyed
- 8 = cylindrical keyed

3. Bearings:

- no code = roller bearings
- G = spherical roller bearings

4. Other options:

- U = without shaft seal
- SV = stainless steel shaft sleeve
corr. protect. for shaft seal
- V = Vyton seals
- I = case press. relief valve 3 bar

DISTRIBUTOR CODE see page *

5. Distributor: D40 standard

6. Tachometer: K = predisposed for tachometer
J = with tachometer coupling

ASSEMBLY CODES

7. Direction of shaft rotation: standard motors are supplied with clockwise rotation (viewed from shaft end) with flow in port A, out port B.

- R = clockwise rotation
- L = anti-clockwise rotation

8. Distributor cover position: see page 8

- no code = position DM1
- DM . , = other position

CODICE MOTORE

1. Cilindrata nominale - vedi tabella cilindrate.

2. Opzioni albero:

- 7 = maschio 65-3-20 DIN 5480
- 1 = maschio 56 UNI 221
- 9 = femmina 55-3-17 DIN 5480
- 3 = femmina A 55-50 DIN 5482
- 2 = conico con chiavetta
- 8 = cilindrico con chiavetta

3. Cuscinetti:

- nessun codice = cuscinetti a rulli
- G = cuscinetti a rulli di botte

4. Altre opzioni:

- U = senza tenuta albero
- SV = manicotto inox sull'albero
protez. anticorros. per tenuta
- V = Tenute in Vyton
- I = valv. sfiato 3 bar

CODICE DISTRIBUTORE vedi pagina *

5. Distributore: D40 standard

6. Contagiri: K = predisposizione per contagiri
J = con attacco contagiri

CODICI PER L'ASSEMBLAGGIO

7. Rotazione albero: i motori sono forniti con rotazione in senso orario (visto dal lato albero) con flusso in ingresso in port A, in uscita port B.

- R = rotazione in senso orario
- L = rotazione in senso anti-orario

8. Posiz. coperchio distributore: vedi pag. 8

- nessun codice = posizione DM1
- DM . , = altra posizione